



Fybroc Division

SERIES 2530

ASME/ANSI SPECIFICATION
B73.1 DIMENSIONS

SERIES 2630

SELF-PRIMING



Close Coupled Sealless Pumps

BULLETIN 25B1

FYBROC SERIES 2530 CLOSE-COUPLED SEALLESS PUMPS

- Capacities to 650 GPM (150 m³/hr)
- Heads to 400 feet (125 m)
- Powers to 40 HP (30 kw)
- Temperatures to 200°F (93°C)
- Working Pressures to 200 PSI (1,380 kPa)
- Eight pump sizes
- Materials of construction availability:
VR-1, VR-1 BPO-DMA, EY-2

FEATURES

- "All-FRP", continuous strand, thermoset construction
- Sealless design
- **NO** separate liner concerns
- Separate impeller and inner magnet assembly
- Stationary, self-aligning, sintered silicon carbide shaft
- Interchangeable front and rear thrust bearings
- ASME/ANSI B73.1 dimensioned
- Zero emissions/leakage
- Simple operation and ease of maintenance

APPLICATIONS & SERVICES

- Chemical Processes
- Metal Finishing
- Pharmaceutical
- Food Processing
- Scrubber OEMs
- Semi-Conductor
- Printed Circuit Boards
- Rail Car/Tank Unloading
- Water and Wastewater Treatment
- Pulp and Paper
- Automotive
- Battery Manufacturers
- General Industrial
- Hydrochloric Acid
- Sodium Hydroxide
- Sodium Hypochlorite
- Sulfuric Acid
- Ferric/Ferrous Chloride
- Nitric Acid
- Chromic Acid
- Solvents
- Specialty Chemicals



VR-1
Construction



EY-2
Construction

SIMPLE, RELIABLE AND COST EFFECTIVE

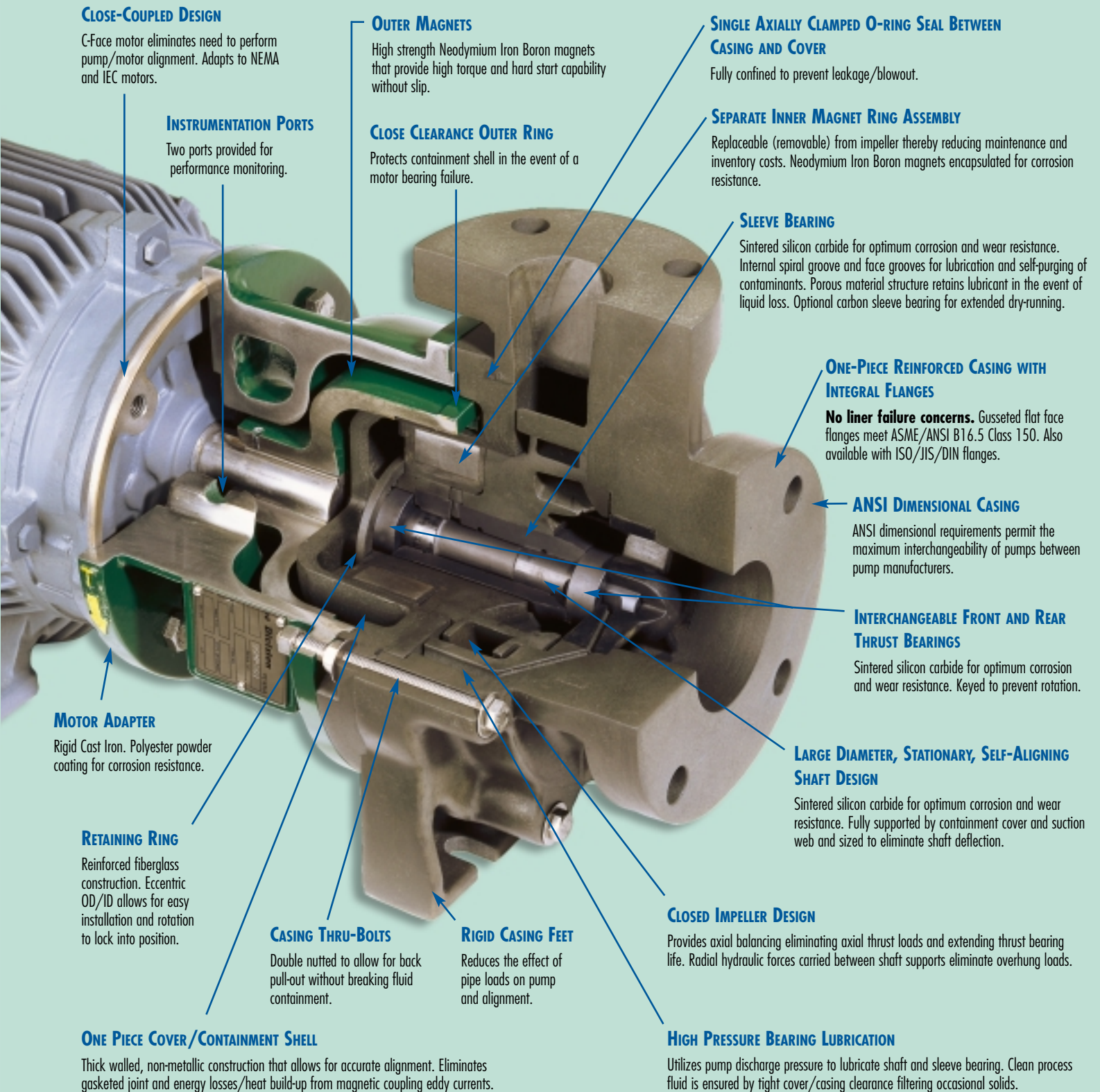

CLOSE-COUPLED DESIGN

C-Face motor eliminates need to perform pump/motor alignment. Adapts to NEMA and IEC motors.

INSTRUMENTATION PORTS

Two ports provided for performance monitoring.

OUTER MAGNETS

High strength Neodymium Iron Boron magnets that provide high torque and hard start capability without slip.

CLOSE CLEARANCE OUTER RING

Protects containment shell in the event of a motor bearing failure.

SINGLE AXIALLY CLAMPED O-RING SEAL BETWEEN CASING AND COVER

Fully confined to prevent leakage/blowout.

SEPARATE INNER MAGNET RING ASSEMBLY

Replaceable (removable) from impeller thereby reducing maintenance and inventory costs. Neodymium Iron Boron magnets encapsulated for corrosion resistance.

SLEEVE BEARING

Sintered silicon carbide for optimum corrosion and wear resistance. Internal spiral groove and face grooves for lubrication and self-purging of contaminants. Porous material structure retains lubricant in the event of liquid loss. Optional carbon sleeve bearing for extended dry-running.

ONE-PIECE REINFORCED CASING WITH INTEGRAL FLANGES

No liner failure concerns. Gusseted flat face flanges meet ASME/ANSI B16.5 Class 150. Also available with ISO/JIS/DIN flanges.

ANSI DIMENSIONAL CASING

ANSI dimensional requirements permit the maximum interchangeability of pumps between pump manufacturers.

INTERCHANGEABLE FRONT AND REAR THRUST BEARINGS

Sintered silicon carbide for optimum corrosion and wear resistance. Keyed to prevent rotation.

MOTOR ADAPTER

Rigid Cast Iron. Polyester powder coating for corrosion resistance.

RETAINING RING

Reinforced fiberglass construction. Eccentric OD/ID allows for easy installation and rotation to lock into position.

CASING THRU-BOLTS

Double nutted to allow for back pull-out without breaking fluid containment.

RIGID CASING FEET

Reduces the effect of pipe loads on pump and alignment.

LARGE DIAMETER, STATIONARY, SELF-ALIGNING SHAFT DESIGN

Sintered silicon carbide for optimum corrosion and wear resistance. Fully supported by containment cover and suction web and sized to eliminate shaft deflection.

CLOSED IMPELLER DESIGN

Provides axial balancing eliminating axial thrust loads and extending thrust bearing life. Radial hydraulic forces carried between shaft supports eliminate overhung loads.

ONE PIECE COVER/CONTAINMENT SHELL

Thick walled, non-metallic construction that allows for accurate alignment. Eliminates gasketed joint and energy losses/heat build-up from magnetic coupling eddy currents.

HIGH PRESSURE BEARING LUBRICATION

Utilizes pump discharge pressure to lubricate shaft and sleeve bearing. Clean process fluid is ensured by tight cover/casing clearance filtering occasional solids.

FYBROC SERIES 2530 – DESIGN FEATURES

FIGURE 1

- Separate impeller and inner magnet ring assembly
- Replaceable (removable) from impeller thereby reducing routine maintenance and inventory costs
- Neodymium Iron Boron magnets encapsulated with 1/8" fiberglass corrosion protection
- Closed impeller design with low stress hex drive

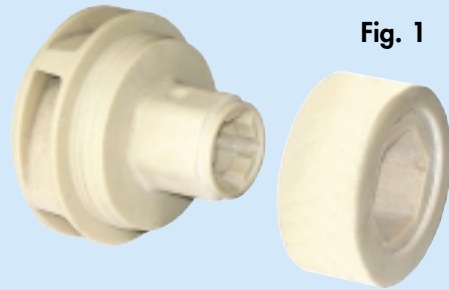

Fig. 1

FIGURE 2

- One-piece reinforced (ASME/ANSI dimensioned) casing with integral, gusseted flanges
- **NO SEPARATE LINER FAILURE CONCERNS**
- Expanded suction eye to compensate for suction web, thereby yielding lower NPSH requirements

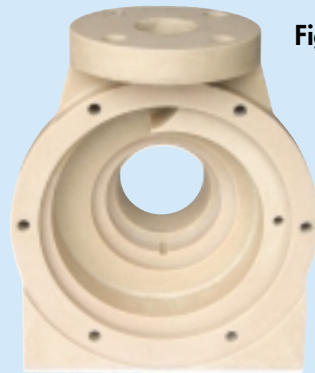
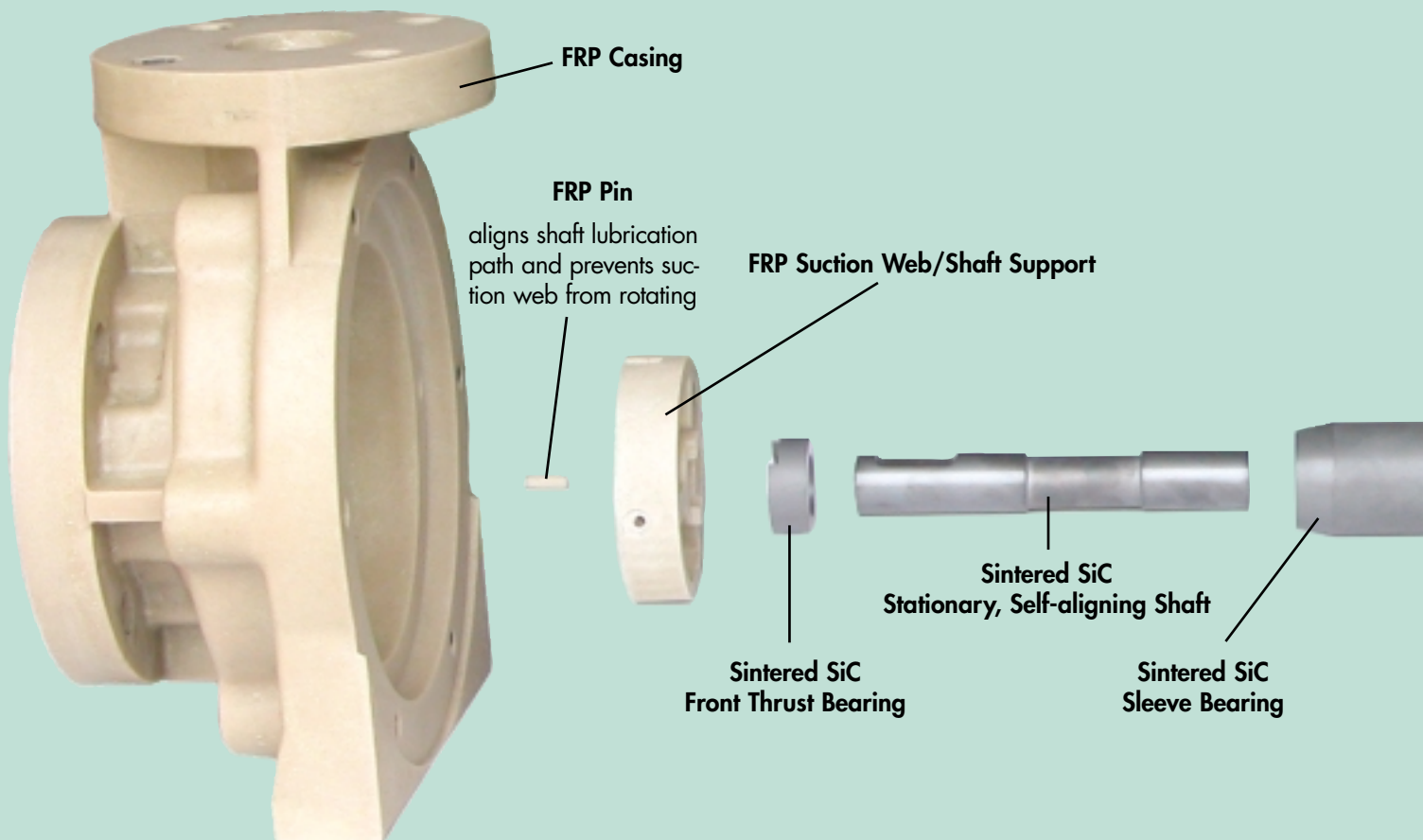

Fig. 2



ASSEMBLED PUMP END



CONTAINED LIQUID END WITH OUTER MAGNET ASSEMBLY AND PUMP ADAPTER REMOVED

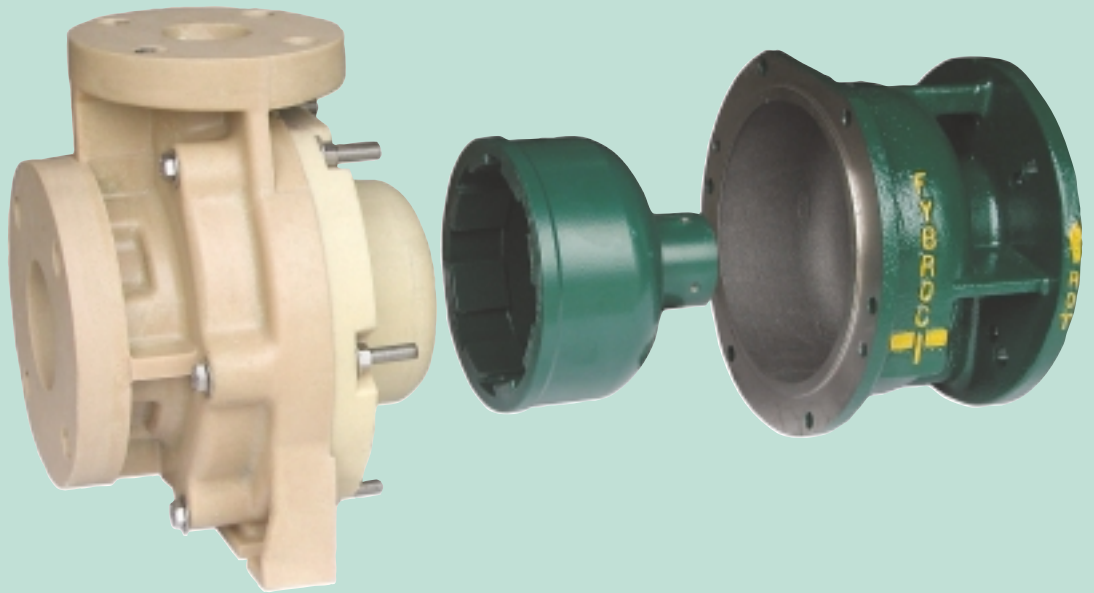

FRP Axially Balanced, Closed Impeller

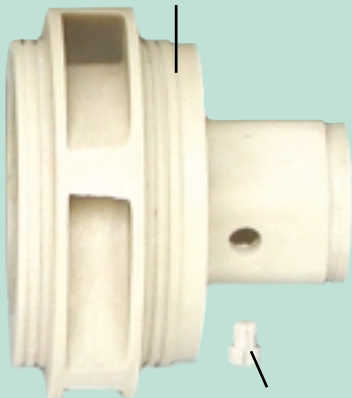

FRP Bearing Pin

drives sleeve bearing and is held in place by inner magnet ring and pin shoulder

Inner Magnet Ring with FRP Corrosion Protection



O-ring
Sintered SiC Rear Thrust Bearing

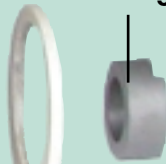

FRP Reinforced Eccentric OD/ID Retaining Ring



One-piece FRP Cover/Containment Shell

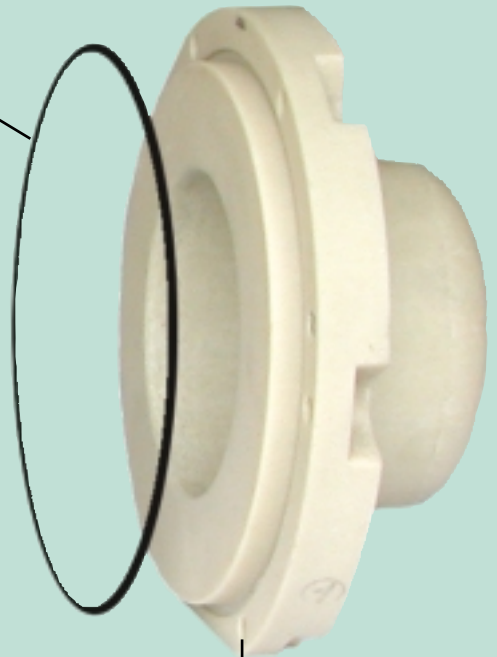

FYBROC SERIES 2530 – PARTS AND STANDARD MATERIALS OF CONSTRUCTION

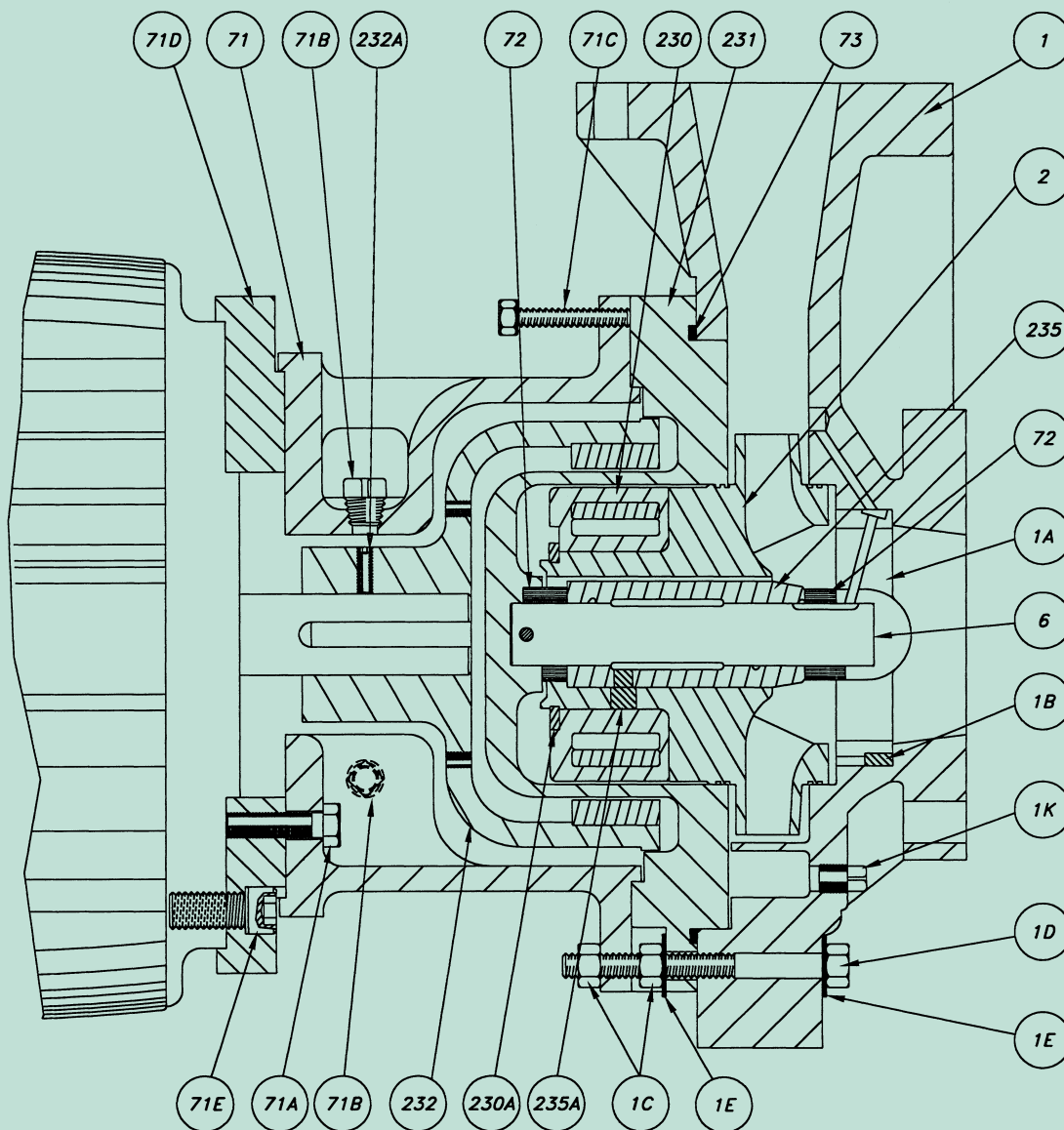

PART NO.	DESCRIPTION	QUANTITY	MATERIAL	PART NO.	DESCRIPTION	QUANTITY	MATERIAL
1	Casing	1	Vinyl Ester	71C	Jack Screw, Adapter	2-3	303 SS
1A	Web, Shaft Support	1	Vinyl Ester	71D	Motor Adapter (if required)	1	Cast Iron
1B	Pin, Casing	1	Vinyl Ester	71E	Screw, Motor Adapter (if required)	4	303 SS
1C	Nut, Casing	12-16	303 SS	72	Bearing, Thrust	2	Silicon Carbide
1D	Bolt, Casing	6-8	303 SS	73	O-ring, Shell	1	Viton
1E	Washer, Casing	12-16	303 SS	230	Magnet Assembly, Inner	1	Vinyl Ester
1K	Plug, Drain (opt.)	1	Teflon	230A	Retaining Ring	1	Vinyl Ester
2	Impeller	1	Vinyl Ester	231	Shell, Cover	1	Vinyl Ester
6	Shaft	1	Silicon Carbide	232	Magnet Assembly, Outer	1	Cast Iron
71	Adapter	1	Cast Iron	232A	Set Screw	2	Steel
71A	Screw, Adapter	4	303 SS	233	Bearing, Sleeve	1	Silicon Carbide
71B	Plug, Adapter	2	Steel	235A	Pin, Bearing	1	Vinyl Ester

FYBROC SERIES 2530 – PUMP DIMENSIONS

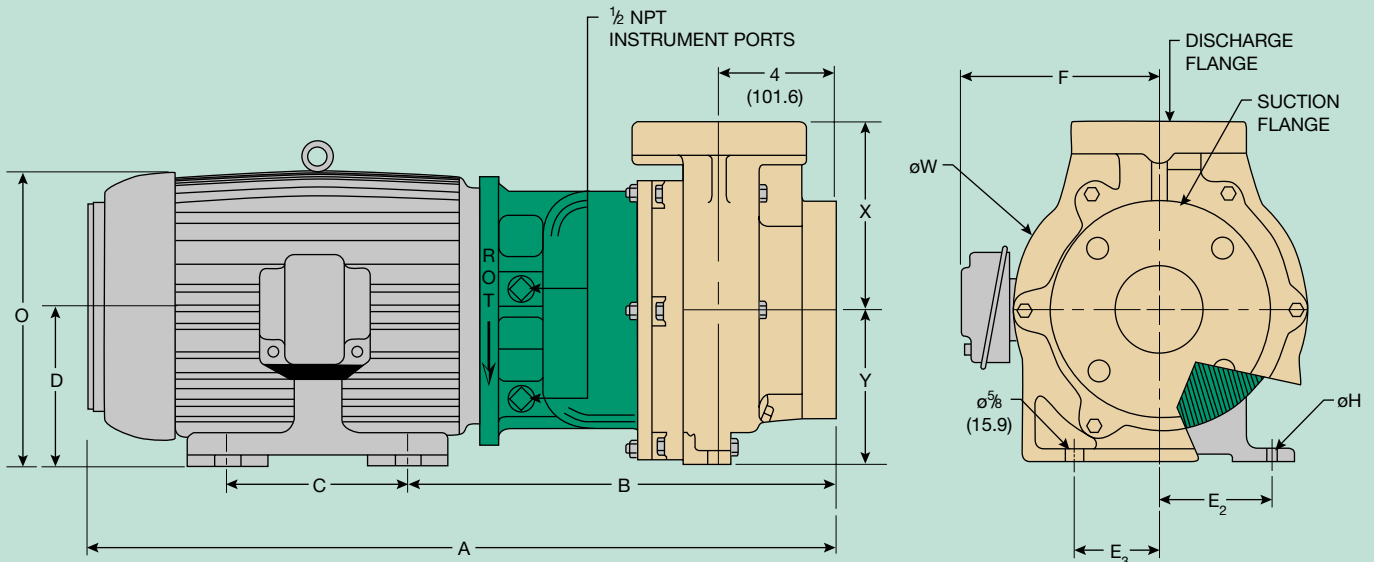

SERIES 2530 GROUP I									
MOTOR	A (1)	B (1)	C	D	E2	E3	F (1)	oH	O (1)
143TC	23 ¹ / ₄	14 ¹⁷ / ₃₂	4 101.6	3 ¹ / ₂	2 ³ / ₄		7	11 ¹ / ₃₂	7 ¹ / ₂
145TC	590.6	369.1	5 127.0	88.9	69.9		177.8	8.7	190.5
182TC	25 ¹ / ₈	15 ¹ / ₃₂	4 ¹ / ₂ 114.3	4 ¹ / ₂	3 ³ / ₄	3	7 ⁵ / ₈	7 ⁷ / ₁₆	9 ¹ / ₂
184TC	638.2	381.8	5 ¹ / ₂ 139.7	114.3	95.3	76.2	193.7	11.1	241.3
213TC	28 ⁵ / ₈	15 ²⁹ / ₃₂	5 ¹ / ₂ 139.7	5 ¹ / ₄	4 ¹ / ₄		11 ¹ / ₈	7 ⁷ / ₁₆	11 ¹ / ₂
215TC	727.1	404.0	7 177.8	133.3	108.0		282.6	11.1	292.1
SERIES 2530 GROUP II									
182TC	26 ¹ / ₂	16 ¹ / ₂	4 ¹ / ₂ 114.3	4 ¹ / ₂	3 ³ / ₄		7 ⁵ / ₈		9 ¹ / ₂
184TC	673.1	419.1	5 ¹ / ₂ 139.7	114.3	95.3		193.7	7 ⁷ / ₁₆	241.3
213TC	30	17 ³ / ₈	5 ¹ / ₂ 139.7	5 ¹ / ₄	4 ¹ / ₄		11 ¹ / ₈	11.1	11 ¹ / ₂
215TC	762.0	441.3	7 177.8	133.3	108.0		282.6		292.1
254TC	34 ¹ / ₈	18 ¹ / ₈	8 ¹ / ₄ 209.6	6 ¹ / ₄	5	4 ⁷ / ₈	11 ⁵ / ₈		13 ¹ / ₂
256TC	866.8	460.4	10 254.0	158.8	127.0	123.8	295.3	17 ¹ / ₃₂	342.9
284TSC	37 ¹ / ₈	18 ³ / ₄	9 ¹ / ₂ 241.3	7	5 ¹ / ₂		12 ¹ / ₈	13.5	14 ¹ / ₈
286TSC	943.0	476.3	11 279.4	177.8	139.7		308.0		358.8
324TSC	39 ³ / ₄ 1009.7	20 ⁷ / ₁₆	10 ¹ / ₂ 266.7	8	6 ¹ / ₄		13 ⁵ / ₈	21 ¹ / ₃₂	15 ³ / ₄
326TSC	41 ¹ / ₄ 1047.8	519.1	12 304.8	203.2	158.8		346.1	16.7	400.1

SERIES 2530 GROUP I					
PUMP SIZE	SUCT.	DISCH.	X	Y	oW
1X1 ¹ / ₂ X6	1 ¹ / ₂	1			
1 ¹ / ₂ X3X6	3	1 ¹ / ₂	6 ¹ / ₂	5 ¹ / ₄	10 ¹ / ₈
2X3X6	3	2	165.1	133.3	257.2
1X1 ¹ / ₂ X8	1 ¹ / ₂	1			
SERIES 2530 GROUP II					
3X4X6	4	3	8 ¹ / ₄ 209.6		
2X3X8	3	2	9 ¹ / ₂ 241.3	8 ¹ / ₄	14 ¹ / ₄
3X4X8	4	3	11 279.4	209.6	362.0
1X2X10	2	1	8 ¹ / ₂ 215.9		

FLANGE	O.D.	THICK.	B.C.	NO. OF HOLES	SZ. OF HOLES
1	4 ¹ / ₄ 108.0	7 ⁷ / ₈ 22.2	3 ¹ / ₈ 79.4		5 ⁵ / ₈
1 ¹ / ₂	5 127.0		3 ⁷ / ₈ 98.4	4	15.9
2	6 152.4	1 ¹ / ₈ 28.6	4 ³ / ₄ 120.7		
3	7 ¹ / ₂ 190.5		6 152.4		3 ³ / ₄
4	9 228.6	1 ¹ / ₄ 31.8	7 ¹ / ₂ 190.5	8	19.1

(1) Motor dimensions may vary depending on manufacturer
 All dimensions in inches and millimeters
 Flanges are ASME/ANSI B16.5 Class 150 Flat Face
 Adapts to NEMA/IEC motors. Consult factory for flange configuration required to mount IEC motors.

FYBROC SERIES 2530 – PUMP COVERAGE

1150 RPM

60 HERTZ

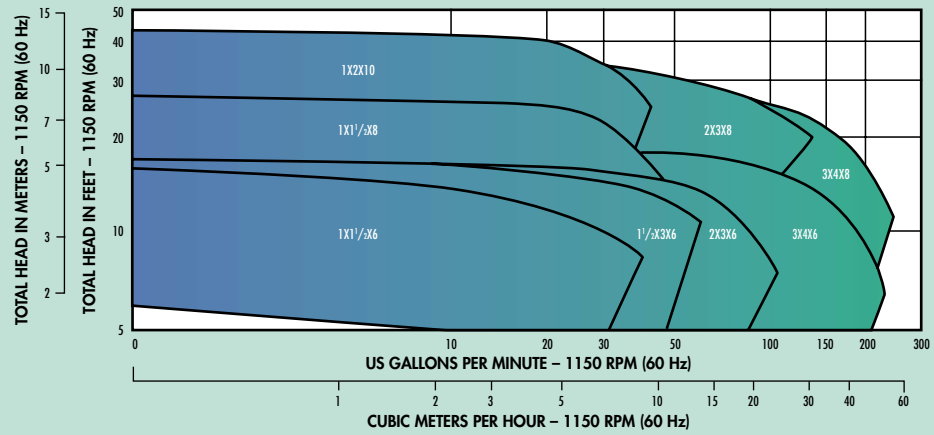

US GALLONS PER MINUTE – 1450 RPM (50 Hz)

CUBIC METERS PER HOUR – 1450 RPM (50 Hz)

1750/1450 RPM

60/50 HERTZ

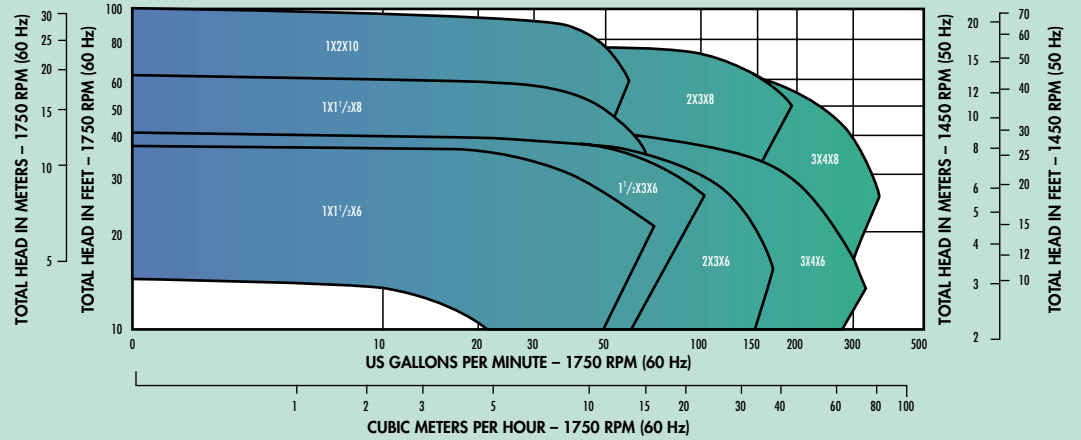

US GALLONS PER MINUTE – 2900 RPM (50 Hz)

CUBIC METERS PER HOUR – 2900 RPM (50 Hz)

3500/2900 RPM

60/50 HERTZ

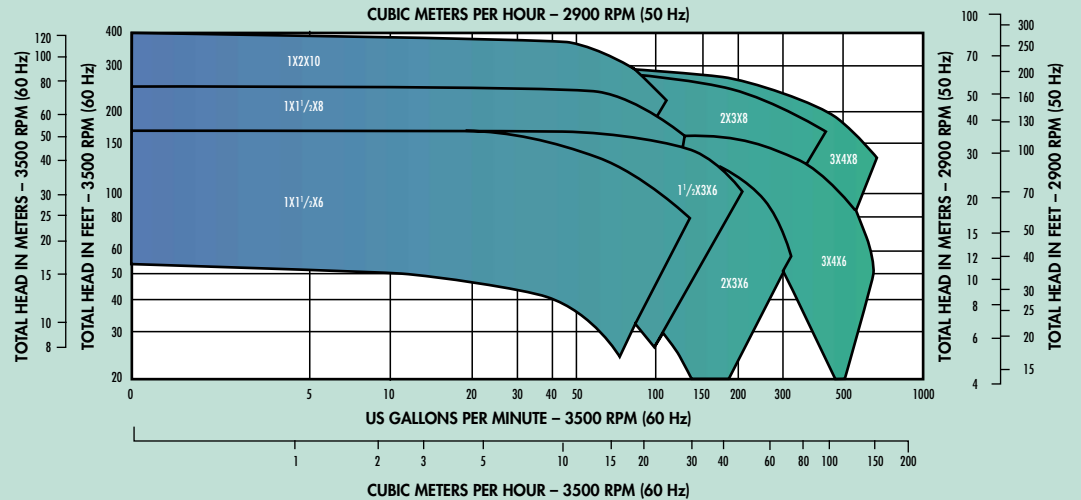

NOTE: For specific performance curves www.fybroc.com.

HIGH PRESSURE BEARING LUBRICATION PATH

- Bearing lubrication path taken off of high pressure area
- Filters occasional solids out of the lubrication flow path
- Solid size restricted by the nominal 1/16" casing/cover clearance
- Sleeve bearing contains an integral spiral groove and face grooves for lubrication and self-purging of contaminants

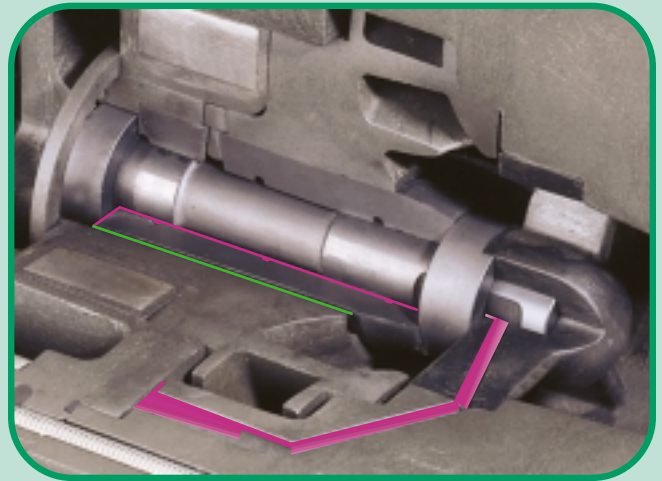

The Fybroc Series 2630 is an FRP, close-coupled, self-priming, magnetic-drive sealless pump that incorporates many of the features found on the Fybroc Series 2530 pumps. With the exception of the casing volute/tank assembly, all components of the Series 2630 are fully interchangeable with those of the Series 2530. The Series 2630 is ideally suited for corrosive sump applications, tank car unloading, and other similar, demanding applications. The volute casing has been designed with optimal proportions in the recirculation chamber to provide for short and efficient priming times, without the use of troublesome check valves. The volute casing inlet

FYBROC SERIES 2630 SELF-PRIMING

- Capacities to 300 GPM (70 m³/hr)
- Heads to 200 feet (65 m)
- Suction Lifts to 20 feet (6 m)
- Two pump sizes

has also been designed to minimize NPSH requirements, thereby leading to greater allowable suction lifts.

An important feature of the Series 2630 is its replaceable volute extension. The casing volute cutwater in any self-priming pump must be in close proximity to the impeller in order to permit efficient priming. The removable volute extension in the Series 2630 is available in a number of sizes to match specific impeller diameters permitting field hydraulic changes and the restoration of priming efficiency, all without casing modifications or replacement.

FYBROC SERIES 2630 SELF-PRIMING – PUMP DIMENSIONS

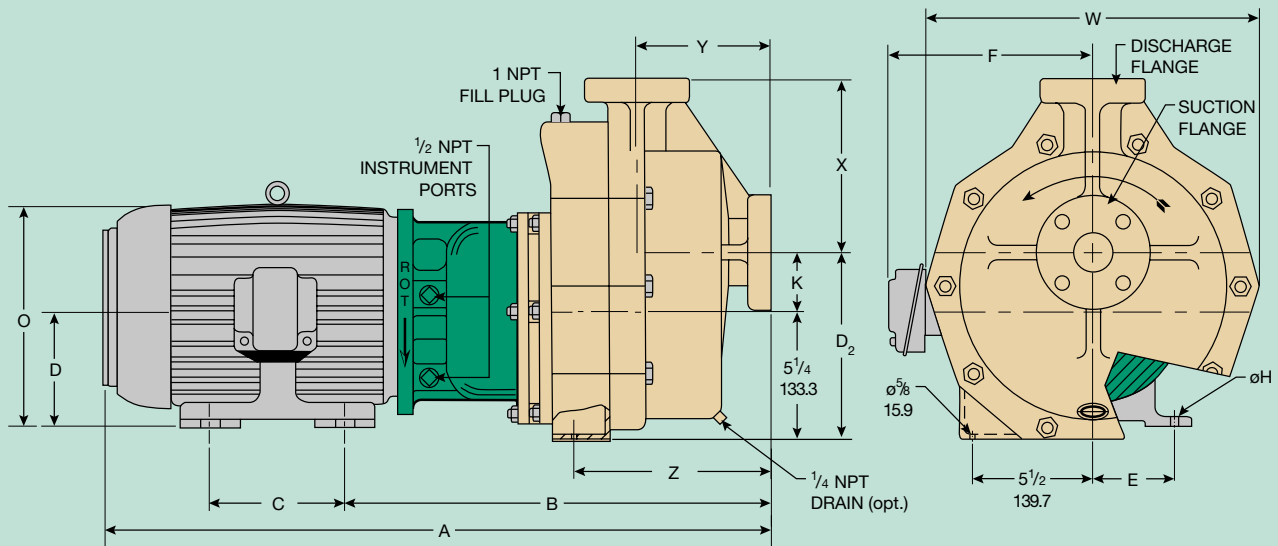

SERIES 2630 SELF-PRIMING GROUP I

MOTOR FRAME	PUMP SIZE	A (1)	B (1)	C	D	E	F (1)	H	O (1)
143TC	1 x 1 1/2 x 8	28 3/8 720.7	19 9/16 496.9	4					
	2 x 3 x 6	30 9/16 776.3	21 3/4 552.5	101.6	3 1/2 88.9	2 3/4 69.9	7 177.8	11/32 8.7	7 1/2 190.5
145TC	1 x 1 1/2 x 8	28 3/8 720.7	19 9/16 496.9	5					
	2 x 3 x 6	30 9/16 776.3	21 3/4 552.5	127.0					
182TC	1 x 1 1/2 x 8	30 3/16 766.8	20 1/16 509.6	4 1/2 114.3					
	2 x 3 x 6	32 3/8 822.3	22 1/4 565.2		4 1/2 114.3	3 3/4 95.3	7 5/8 193.7		9 1/2 241.3
184TC	1 x 1 1/2 x 8	30 3/16 766.8	20 1/16 509.6						
	2 x 3 x 6	32 3/8 822.3	22 1/4 565.2	5 1/2 139.7				7/16 11.1	
213TC	1 x 1 1/2 x 8	33 11/16 855.7	20 15/16 531.8						
	2 x 3 x 6	35 7/8 911.2	23 1/8 587.4		5 1/4 133.3	4 1/4 108.0	11 1/8 282.6		11 1/2 292.1
215TC	1 x 1 1/2 x 8	33 11/16 855.7	20 15/16 531.8	7					
	2 x 3 x 6	35 7/8 911.2	23 1/8 587.4	177.8					

SERIES 2630 SELF-PRIMING GROUP I

PUMP SIZE	SUCT.	DISCH.	D ₂	K	W	X	Y	Z
1 X 1 1/2 X 8	1 1/2	1	8 7/8 225.4	3 5/8 92.1	14 3/8 365.1	7 177.8	6 152.4	9 5/16 236.5
2 X 3 X 6	3	2	9 1/8 231.8	3 7/8 98.4	17 5/8 447.7	9 1/8 231.8	7 177.8	11 1/2 292.1

FLANGE	O.D.	THICK.	B.C.	NO. OF HOLES	SZ. OF HOLES
1	4 1/4 108.0	1 25.4	3 1/8 79.4	4	5/8 15.9
1 1/2	5 127.0	1 1/8 28.6	3 7/8 98.4		3/4 19.1
2	6 152.4		4 3/4 120.7		
3	7 1/2 190.5	6 152.4			

(1) Motor dimensions may vary depending on manufacturer
 All dimensions in inches and millimeters
 Flanges are ASME/ANSI B16.5 Class 150 Flat Face
 Adapts to NEMA/IEC motors. Consult factory for flange configuration required to mount IEC motors.

FYBROC SERIES 2630 SELF-PRIMING – PARTS AND STANDARD MATERIALS OF CONSTRUCTION

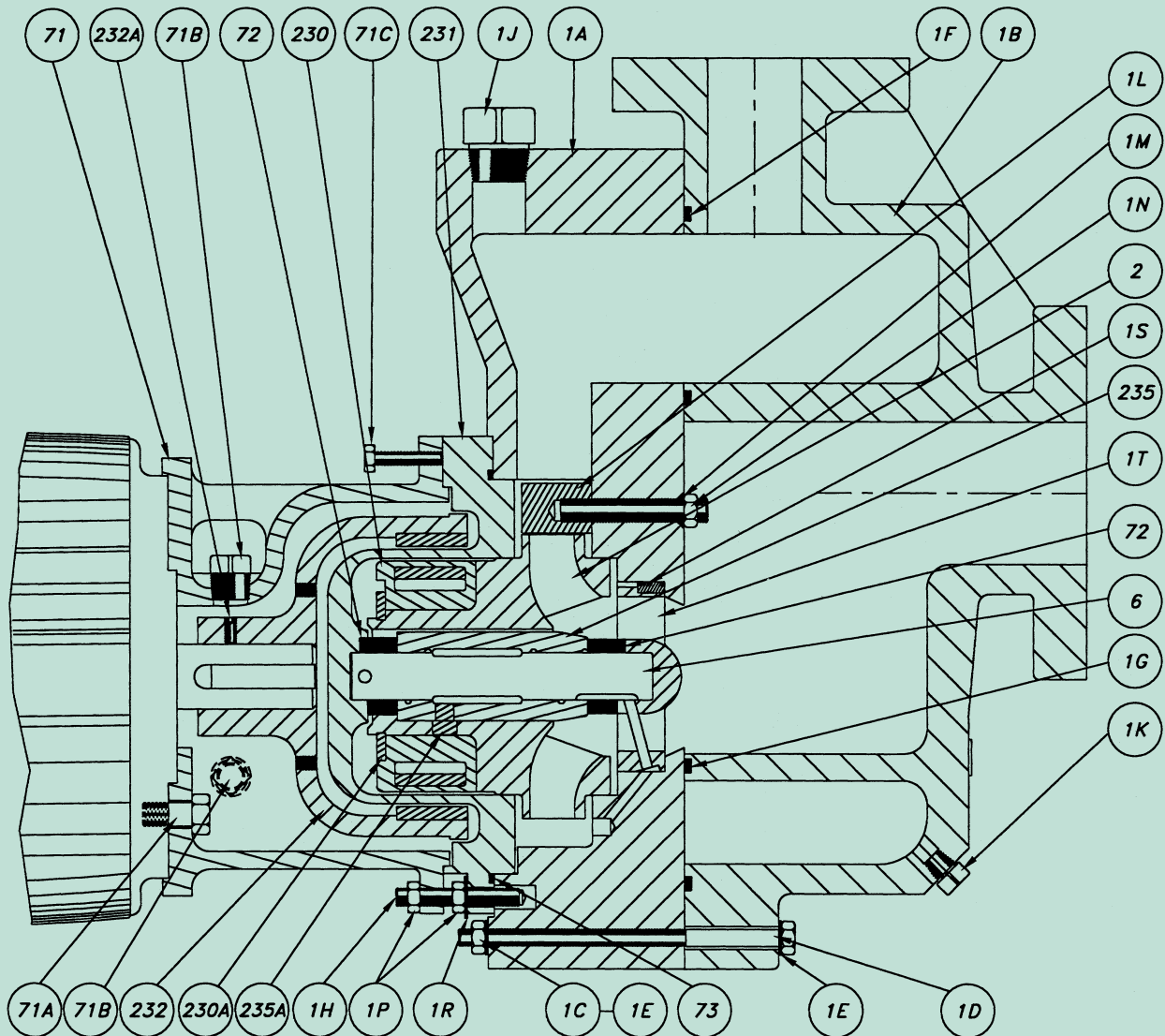

PART NO.	DESCRIPTION	QUANTITY	MATERIAL	PART NO.	DESCRIPTION	QUANTITY	MATERIAL
1A	Casing Volute	1	Vinyl Ester	1T	Web, Shaft Support	1	Vinyl Ester
1B	Casing Tank	1	Vinyl Ester	2	Impeller	1	Vinyl Ester
1C	Casing Nut	8-10	303 SS	6	Shaft	1	Silicon Carbide
1D	Casing Bolt	8-10	303 SS	71	Adapter	1	Cast Iron
1E	Casing Washer	16-20	303 SS	71A	Screw, Adapter	4	303 SS
1F	O-ring, Discharge	1	Viton	71B	Plug, Adapter	2	Steel
1G	O-ring, Suction	1	Viton	71C	Jack Screw, Adapter	2	303 SS
1H	Stud, Casing	6	303 SS	72	Bearing, Thrust	2	Silicon Carbide
1J	Fill Plug	1	Polypro	73	O-ring, Shell	1	Viton
1K	Drain Plug (opt.)	1	Teflon	230	Magnet Assembly, Inner	1	Vinyl Ester
1L	Volute Insert	1	Vinyl Ester	230A	Retaining Ring	1	Vinyl Ester
1M	O-ring, Insert	1-2	Viton	231	Shell, Cover	1	Vinyl Ester
1N	Nut, Insert	1-2	Vinyl Ester	232	Magnet Assembly, Outer	1	Cast Iron
1P	Nut, Casing	12	303 SS	232A	Set Screw	2	Steel
1R	Washer, Casing	6	303 SS	235	Bearing, Sleeve	1	Silicon Carbide
1S	Pin, Casing	1	Vinyl Ester	235A	Pin, Bearing	1	Vinyl Ester



Fybroc Division

700 Enlen Way, Telford, PA 18969
TOLL-FREE: 1-800-FYBROC-1, Phone: (215) 723-8155, FAX: (215) 723-2197
E-Mail: sales@fybroc.com, Web Site: www.fybroc.com



AMERICAN ZOO AND AQUARIUM ASSOCIATION



AALSO

The world's most complete line
of pumps for handling corrosive
and other difficult liquids

